

VAF

INSTRUMENTS



MidFlow[®] / HiFlow[®]

Sliding Vane Meters DN 25-300 (1"-12")

I27

Product Bulletin

WWW.VAF.NL

TO BE
REALLY
SURE

Introduction

VAF Instruments MidFlow®/HiFlow® positive displacement type liquid Flowmeters are used in continuous metering applications, in-line blending processes and batch applications. MidFlow®/HiFlow® Flowmeters have a simple, rugged design. With only few almost frictionless moving internal parts there is hardly any wear in the Flowmeter which safeguards a typical long lasting lifetime. MidFlow®/HiFlow® meters have no mechanical seals saving you from regular maintenance and possible leakage of process liquids into the environment. The Flowmeter is driven by the process liquid which makes it suitable for distant locations without power supply. The high accuracy of the Flowmeter (better than 0,1% and repeatability 0,05%) is not influenced by process pressure or temperature, mechanical pipe strain or liquid turbulence and therefore straight inlet and outlet pipe pieces are not required.

Experience in flow measurement

In 1938 VAF Instruments started as a manufacturer of petrol delivery pumps. The Flowmeters made by VAF for this pump already had to have the highest accuracy and had to meet the demands of the board of weights and measures. Innovation and research over the past 80 years helped VAF to make new types of Flowmeters bearing in mind customer requirements and the need for accurate flow measurement. VAF Instruments Flowmeters are available in sizes from 8 mm up to 300 mm (l/hr up to 960 m³/hr). MidFlow®/HiFlow® Flowmeters cover the middle and high part of this range.

Available MidFlow®/HiFlow® meters

MidFlow®/HiFlow® Flowmeters are available in connection sizes from 25 mm up to 300 mm representing maximum flow ranges from 160 l/min up to 16000 l/min. A choice of material is available with ductile iron, steel and stainless steel. For registration of the measured amount of liquid, VAF MidFlow®/HiFlow® meters can be fitted with various combinations of counters and pulse transmitters.

Liquids

VAF positive displacement series Flowmeters MidFlow®/HiFlow® are suitable for a wide range of liquids. Because liquids with higher viscosities do not degrade the accuracy of the sliding vane Flowmeter, it is possible to use only one Flowmeter for various liquids.

Principle of operation

VAF Instruments positive displacement Flowmeters operate on the sliding vane principle. The meter consists of a specially shaped housing in which a rotor can rotate freely. Two pairs of vanes are placed into four slots in the rotor. Each pair is positioned by a rod and can move in and out of the rotor. The radial movement of the vanes is guided by the special inner shape of the housing. This innovative construction provides a constant seal between the inlet and the outlet of the meter. The incoming liquid forces the rotor to rotate. The rotation of the rotor is transferred via a magnetic coupling to a read out device. This can be a counter in any desired engineering unit or a pulse transmitter for remote read out, flow data processing or connection to a process computer.

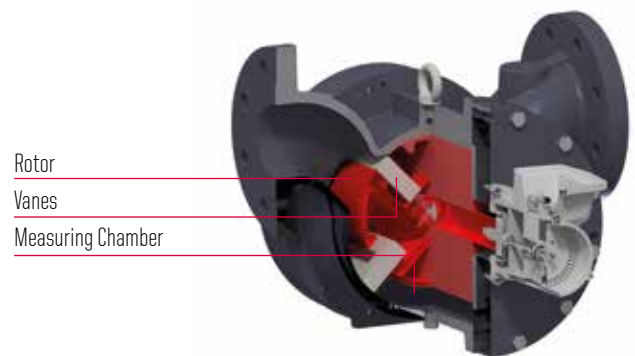

Sectional view of a Flowmeter

Applications

Some of the many applications are:

- Fuel consumption measurement of combustion engines and oil burners;
- Blending of additives in the process industry;
- Fuel oil bunkering and blending;
- Addition of catalysts to chemical reactors;
- Coating of sheet materials;
- Injection of oils and fats in the foodstuffs and animal feed industries;
- Flow control of dosing pumps;
- Dosing of additives in cement concrete preparation;
- Measurement of liquid movement in hydraulic systems;
- Accurate measurement of viscous liquids at low flowrates;
- Dosing of liquids in the paint, tobacco and beverage industries.



Bunkering

Design features

VAF Flowmeters are designed to have an unrivalled superior accuracy over a large measuring range, which is not degraded by conditions like e.g. viscosity, temperature or flow pattern. VAF Flowmeters feature a rugged design to be used in industrial environments and due to only few internal parts, maintenance and operational costs are low, as wear is kept to a minimum. The designs standards include MID (European custody transfer), PED (European pressure vessels) and ATEX for hazardous areas.

Options and accessories

VAF MidFlow®/HiFlow® meters can be fitted with various combinations of counters and pulse transmitters, which also allows them to be connected to flow computers for totalising, registering, printing, batching or controlling the liquid flows. The larger platforms of dedicated hardware and software also make combinations with other types of instrumentation possible to enable additional functionality; e.g. mass flow when combined with VAF ViscoSense® 3D density sensors or temperature compensated readings when combined with (integrated) temperature sensors.



HiFlow® meter



VR register



FCM2

Dimensions

MidFlow®

All dimensions apply for Flowmeters with DIN PN 10/16/25 flanges.
 Dimensions of Flowmeters with other pressure rating are available on application.
 All dimensions are in millimetres

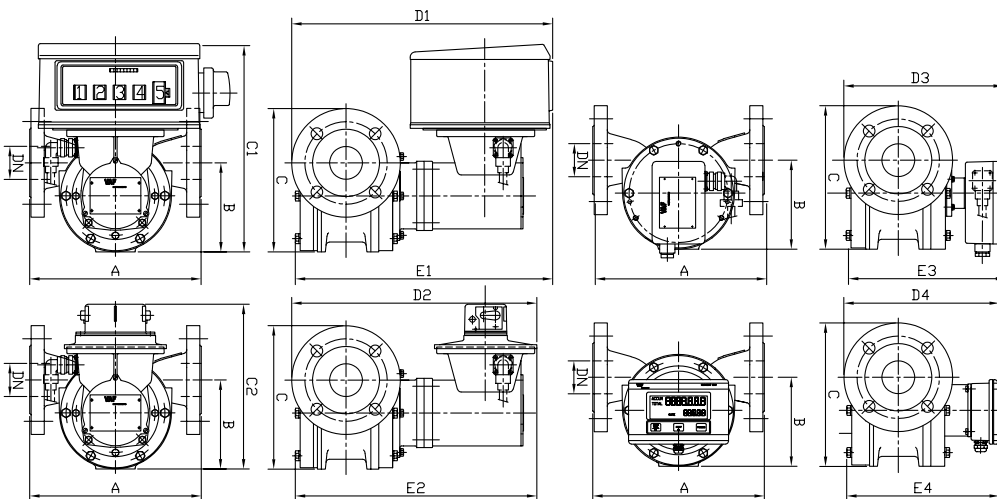

MidFlow®

Basic model number	J1025	J5025	J3025	J1040	J5040	J3040	J1050	J5050	J3050	J1080	J5080	J3080	J1100	J5100	J3100
Connection size	DN 25			DN 40			DN 50			DN 80			DN 100		
A	240			240			260			400			450		
B	110			110			135			243			285		
C	168			185			218			343	345	343	395	397	395
C1	300			300			315			373			400		
D1	350	354	368	372	397	395	403	477	470	494	511	504	550		
E1	348	365	348	365	393	389	413	520	502	563	570	552	638		
C2	235			235			250			308			335		
D2	326	330	343	347	372	370	378	452	445	469	487	480	526		
E2	324	340	324	340	369	365	389	496	478	538	546	528	613		
D3	240	244	258	262	387	285	293	367	360	384	401	394	440		
E3	238	255	238	255	283	279	303	410	392	453	460	442	528		
D4	217	221	235	239	264	262	270	344	337	361	378	371	417		
E4	215	232	215	232	260	256	280	387	369	430	437	419	505		

HiFlow®

All dimensions apply for Flowmeters with DIN PN 10 flanges. Dimensions of Flowmeters with other pressure rating are available on application. All dimensions are in millimetres

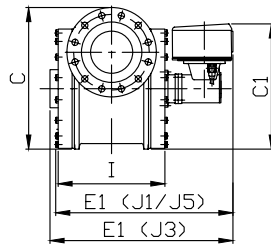
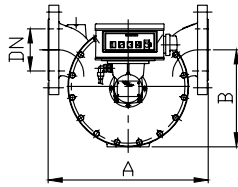

Model no. J5150 and J5200

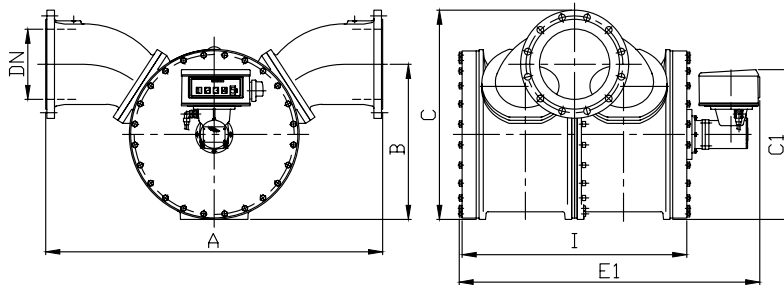

Model no. J5250 and J5300

Basic model number	J5150	J5200	J5250	J5300
Connection size	DN150	DN200	DN250	DN300
A	550	900	1200	
B	345	528	553	578
C	487	708	751	801
C1	445	533	533	
D1	555	639	858	883
E1	613	703	1071	
I	360	450	800	

Technical specification

MidFlow®

Basic model number	J5025	J5040	J5050	J5080	J5100	J1025	J1040	J1050	J1080	J1100	J3025	J3040	J3050	J3080	J3100			
Connection size, DN (mm)	25	40	50	80	100	25	40	50	80	100	25	40	50	80	100			
Capacity (l/min)																		
Maximum, 8 hrs/day discontinuous	160	250	500	1900	2750	160	250	500	1900	2750	160	250	500	1900	2750			
Maximum, continuous	120	190	380	1450	2000	120	190	380	1450	2000	120	190	380	1450	2000			
Minimum, range 1:10 ¹	16	25	50	190	275	16	25	50	190	275	16	25	50	190	275			
Minimum, range 1:20 ²	8	12,5	25	80	137,5	8	12,5	25	80	137,5	8	12,5	25	80	137,5			
Displaced volume per revolution (litre)	0,167	0,167	0,4	2,95	5,3	0,167	0,167	0,4	2,95	5,3	0,167	0,167	0,4	2,95	5,3			
Maximum viscosity for maximum flowrate (cSt)⁴	100	100	100	150	150	100	100	100	150	150	100	100	100	150	150			
Measuring accuracy																		
Range 1:10 ¹ better than	± 0,2 %			± 0,1 %			± 0,2 %			± 0,1 %			± 0,2 %			± 0,1 %		
Range 1:20 ² better than	± 0,3 %																	
Repeatability	better than ± 0,05 %																	
Required starting pressure (kPa (bar))	3 (0,03)																	
Materials																		
Body	ductile iron					AISI 316												
Rotor	ductile iron			cast iron		ductile iron			cast iron		AISI 316							
Covers	ductile iron / steel on application					steel					AISI 316							
Vanes	carbon																	
O-rings	Vitron A / PFA covered Vitron A or Kalrez on application										PFA covered Vitron A / Kalrez on application							
Bearings	steel ball bearings / stainless steel ball bearings on application										AISI 316 needle bearings							
Body pressure rating (kPa (bar))	2000 (20)			1050 (10,5)		2500 (25)			2000 (20)		2500 (25)			2000 (20)				
with steel covers	2500 (25)			2000 (20)		not applicable												
Available flanges																		
DIN PN (bar)	PN 10, 16, 25; raised face or with groove acc. DIN 2512N																	
ANSI	150, 300 RF ³																	
JIS (K)	5, 10, 16, 20																	
Liquid temperature range standard	-10 °C to 120 °C for other temperatures consult factory																	
Weight without counter (kg)	13	16	24	78	108	13	16	24	78	108	13	16	24	78	108			

Notes: ¹ standard factory calibration. ² calibration on request. ³ for 300 lbs flanges on 100 mm models consult factory.

⁴ Higher viscosity means a lower maximum flowrate. Please refer to graphs for flowrate-pressure drop-viscosity relation.

Basic model number	J5150	J5200	J5250	J5300
Connection size, DN [mm]	150	200	250	300
Capacity [l/min]				
Maximum, 8 hrs/day discontinuous	4.600	8.000	12.500	16.000
Maximum, continuous	3.450	6.000	9.500	12.000
Minimum, range 1:10 ¹	460	800	1.250	1.600
Minimum, range 1:20 ²	230	400	625	800
Displaced volume per revolution [litre]	11,9	29,3	58,6	
Maximum viscosity for maximum flowrate [cSt] ³	700	400	600	400
Measuring accuracy				
Range 1:10 ¹	± 0,1%			
Range 1:20 ²	± 0,3%			
Repeatability	Better than ± 0,05%			
Required starting pressure [kPa (bar)]	3 (0,03)			
Materials				
Body and covers	ductile iron			
Rotor	cast iron			
Vanes	carbon			
O-rings	Viton A, PFA covered Viton A			
Bearings	steel			
Body pressure rating [kPa (bar)]	1050 (10,5)		1250 (12,5)	
Available flanges				
DIN PN [bar]	10, 16; optional with groove acc. DIN 2512N			
ANSI	150 RF			
JIS [K]	5, 10			
Liquid temperature range standard	-10 °C to 120 °C, for other temperatures consult factory			
Weight without counter [kg]	215	585	1000	1100

¹ Standard calibration. ² Calibration on request. ³ Higher viscosity means a lower maximum flowrate. Please refer to the graphs for flowrate-pressure-drop-viscosity relation.

Note

For liquids with viscosities below 0,5 mPa.s with poor lubricating properties, or flowmeters that are running continuously it is also advisable to reduce the maximum flow, to prevent excessive wear of the vanes. A general rule is to reduce the maximum capacity to 75% of the value specified in the table.

Note to Flow ranges

Lower minimum capacities are possible dependent on liquid viscosity and required measuring accuracy.

Quotation and ordering information

For proper selection of the suitable MidFlow®/HiFlow® meter the following data should be determined:

Liquid data:

1.	Process liquid (trade name or chemical composition):		
2.	Flowrate minimum [l/min]:	continuous [l/min]:	maximum [l/min]:
3.	Operating pressure range [bar]:		allowable pressure drop [bar]:
4.	Operating temperature range [°C] process liquid:	ambient:	
5.	Viscosity at operating conditions: [cSt]		

Flowmeter data:

6.	Basic model number:				
7.	Diameter liquid piping:				
8.	Wetted parts material:	<input type="radio"/> ductile iron	<input type="radio"/> carbon steel	<input type="radio"/> AISI 316	
9.	Connection flanges:	<input type="radio"/> DIN PN [bar]:	<input type="radio"/> ANSI RF [lbs]:	<input type="radio"/> JIS [K]:	
10.	Direction to flow:	<input type="radio"/> left to right	<input type="radio"/> right to left	<input type="radio"/> top to bottom	<input type="radio"/> bottom to top
11.	Local counter:	<input type="radio"/> no built-on counter (continue with step 12)			
		<input type="radio"/> key-resettable totaliser			
		<input type="radio"/> resettable Flowmeter register			
	batch counter:	<input type="radio"/> electrical	<input type="radio"/> pneumatic		
	knock-off:	<input type="radio"/> 1 stage knock-off	<input type="radio"/> 2 stage knock-off		
	<input type="radio"/> ticket printer (on resettable Flowmeter register or batch counter)				
12.	Pulse transmitter:	<input type="radio"/> number of low speed inductive pulse transmitter(s)		preferred pulses/litre	
		<input type="radio"/> number of high speed inductive pulse transmitter(s)		preferred pulses/litre:	
	<input type="radio"/> pulse discriminator, (DIN rail mounting) using 2 inductive pulse transmitters				
	<input type="radio"/> incremental pulse encoder				
13.	Liquid filter:	<input type="radio"/> required	<input type="radio"/> not required		
14.	Special certification:	<input type="radio"/> inspection by customer			<input type="radio"/> standard factory calibration
	<input type="radio"/> inspection by classification authority:				
	<input type="radio"/> factory test and material certificate acc. EN 10204 3.1				
	<input type="radio"/> MID	<input type="radio"/> PED	<input type="radio"/> ATEX	<input type="radio"/> other:	
15.	Tagging	<input type="radio"/> paper tag	<input type="radio"/> stn. stl. tag fixed to Flowmeter		
16.	Other options & accessories:				

Name:

Place and date:

Please fill out this form and send it to sales@vaf.nl. We will reply with a quotation and ordering information for the requested product or solution a.s.a.p.

For further information see relevant Product Bulletins or www.vaf.nl



All copyrights reserved | PB-127-6B-0520 | Superseides PP-127-6B-0614

VAF

INSTRUMENTS

VAF Instruments B.V.
Vierlinghstraat 24, 3316 EL Dordrecht, The Netherlands
P.O. Box 40, 3300 AA Dordrecht, The Netherlands
T +31 78 618 3100 | info@vaf.nl | www.vaf.nl

Specifications subject to change without notice
VAF Instruments B.V. is an ISO 9001 Certified Company
Agents and distributors in more than 50 countries