

VAF

INSTRUMENTS



TT-Sense[®]

Optical Thrust and Torque Measuring Systems
Insight in Propulsion Efficiency

663

Product Bulletin

WWW.VAF.NL

TO BE
REALLY
SURE

Introduction

Since 1938 VAF Instruments is an established name in the world of marine measuring equipment. The need for increased energy performance and necessity to comply to rules and regulations, inspired us to develop the next step in our successful line of sensors: the TT-Sense®. The use of a TT-Sense® means getting more insight in your propeller efficiency, hull resistance and vessel trim optimization. Managing propeller thrust and hull resistance at full scale enable savings up to 20% and in some cases even more. This real thrust measurement is performed by highly accurate optical sensor technology.

Why a thrust and torque measuring system?

Thrust measurement provides you with precise information on propulsion efficiency related to consumed energy. By giving instantaneous read-out of real thrust, torque, speed and power, the effects of operational changes can be monitored. When these effects are visible, you can use your propulsion system in the most efficient way. This will considerably reduce your fuel costs, and beside that it will indicate malfunctions in the propulsion system as early as possible, both being primary cost drivers.

Where is the TT-Sense® thrust and torque measuring system used?

TT-Sense® thrust and torque measuring systems can be used for propulsion installations of all kind. For example for continuous measurement of propeller efficiency or continuous power measurement, as well as continuous trending of thrust, torque, shaft speed and power. Giving direct visual control of changes in resistance or performance due to trimming and hull and propeller fouling of the vessel.

System output

The standard output of the TT-Sense® thrust and torque measuring system consists of a thrust, torque, shaft speed and power signal. The system can be extended with VAF fuel consumption Flowmeters, speedlog/GPS input and a range of nautical and navigational data.

Advantages

Due to a robust design, TT-Sense® thrust and torque measuring systems have a high durability and are able to withstand the typical harsh environmental conditions onboard ships, dredgers and in engine rooms, etc. Innovative optical sensor technology results in a high accuracy. TT-Sense® thrust and torque measuring systems are maintenance free as a result of non-contact power and signal transmission.

Principle of operation

The TT-Sense® thrust and torque measuring system can be mounted on intermediate shafts after the thrust bearing. When a shaft is subject to thrust and torque this results in a small strain at the shaft surface.

LEDs and extremely accurate optical sensors can detect these small displacements, in both axial and radial directions. The measured values are transferred continuously from the rotating shaft to the stator part through wireless data connection. Power transmission from the stator to the rotating shaft is performed by means of induction. The stator part consists of a power transmission coil, a data signal receiver and a control box equipped with digital or analogue output connections. These outputs can be linked directly to the vessels data network, monitoring- or control system.

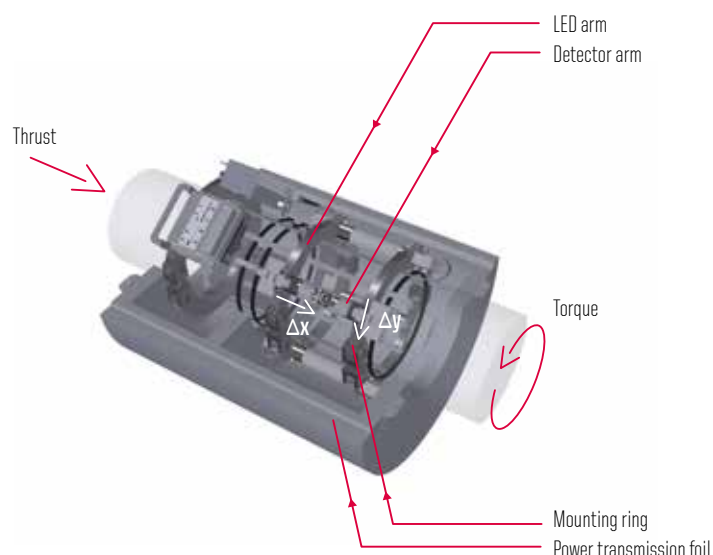

Sectional view

Δy and Δx are small movements of the propeller shaft surface due to strain. Δy is the movement in torque direction and Δx is the movement in thrust direction.

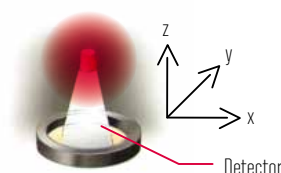

Optical displacement measurement

Typical system arrangement



Ships monitoring

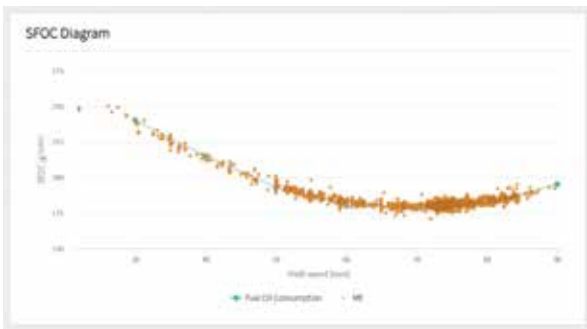

Fault detection



AMS or data acquisition



Fuel density



12x PT2 Flowmeter (flow + temperature) For max. 8 consumers

Nautical / navigational data

Speed log / GPS



TT-Sense®

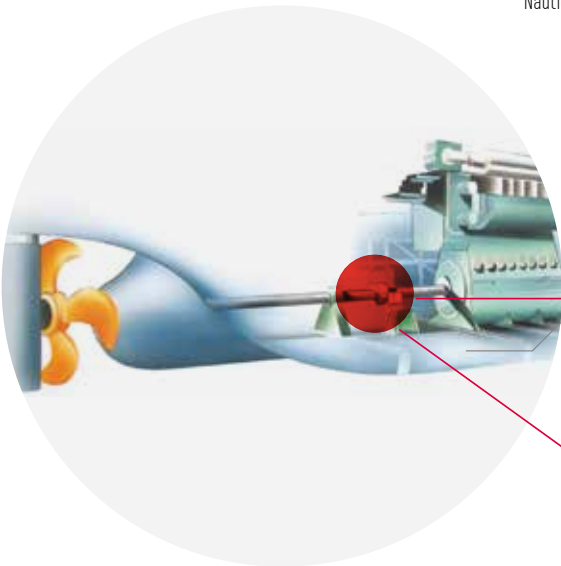

Typical TT-Sense® thrust and torque measuring system with optional fuel consumption measurement

Applications of thrust and torque measurement

By using the TT-Sense® propeller thrust measuring possibilities, the performance of the propeller and hull can be measured separately providing an important input to fuel saving and maintenance investment decisions. Customers have reported savings of up to 20% on fuel and maintenance costs by managing propeller performance and hull resistance at full scale.

In combination with a monitoring or management system, such as VAF Instruments, PEM4 or IVY®, the TT-Sense® measuring system can be used in a variety of applications.

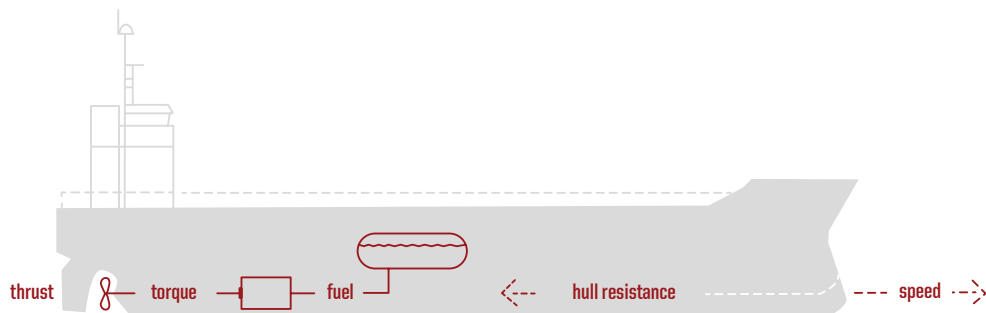

**PROPELLER
EFFICIENCY**

**FUEL
EFFICIENCY**

**HULL
EFFICIENCY**



Energy conversions & efficiencies

Only by measuring propeller thrust you are able to separate the propeller efficiency from the hull resistance

The benefits of measuring torque:

- Determines the total ship resistance change over time.
- Provides insight into engine performance related to consumed fuel.
- Enables optimisation of the efficiency of engine-driven installations to reduce fuel costs.
- Visualisation of engine load margin. Avoiding engine overload.
- Monitoring of torque, speed, power and, when combined with Flowmeters, fuel consumption.
- Direct visual control of the effects of operational changes.
- Torsional vibration analysis for frequencies up to 50 Hz.

The benefits of measuring propeller thrust in addition to torque:

- Enables optimisation of ship's propulsion performance.
- Provides detailed insight in separated performance of propeller and hull.
- Determines the proper individual timing for a hull or propeller cleaning based on the actual hull resistance or propeller performance.
- Direct detailed visualisation of the effects of operational changes.
- Measures hull cleaning and/or new hull coating effects on the ship's resistance.
- Measures propeller cleaning and/or repair effects.
- Determines the optimal settings for propeller efficiency at actual conditions for a controllable pitch propeller.
- Measures new propeller designs, and/or hull designs or modifications (like for instance a new bulbous bow design).
- Measures the effect of Energy Saving Devices
- Detects cavitation.
- Prevents from negative thrust during deceleration, thus avoiding energy waste.
- Continuous, long term trending and analysis of detailed propulsion KPIs.
- Beneficial to compliance with ISO 14001 and/or ISO 19030

Monitoring and management solutions

The TT-Sense® thrust and torque measuring system can be combined with the PEM4 Propulsion Efficiency Monitor, the vessel's monitoring system and/or IVY® Propulsion Performance Management Solution to use the TT-Sense® to its full potential.

IVY® Propulsion Performance Management Solution

IVY®, VAF Instruments' solution for Propulsion Performance Management, brings you the fleet at your fingertips. From ship to shore, IVY® enriches big data for powerful analysis. The web application of IVY® provides fleet and ship performance visualisation and insight into the relevant data and more than 40 KPIs. IVY® can be combined with a range of sensors on board, including TT-Sense®. IVY® brings Big Data back to the essence. A solution for monitoring and management on shore as well as on board is available. Measuring data of sensors like eg. speed through water can be improved by applying IVY® virtual sensors.

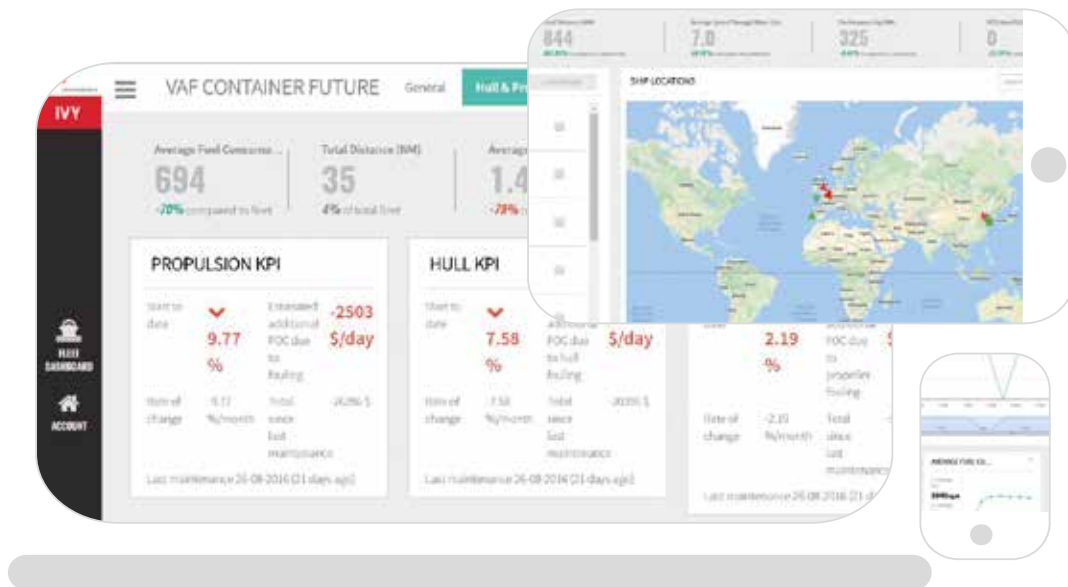

Propulsion Efficiency Monitor (PEM4) + Signal Processing Unit (SPU3)

The PEM4 + SPU3 instantly show torque, shaft power, propeller performance and other selected measuring data. Additional Flowmeter signals and temperature sensor signals enable calculation of the engines fuel consumption including temperature compensation. In combination with input signals from speedlog or GPS, the PEM4 will display the specific fuel consumption per kW and/or per nautical mile.



PEM4 Touch screen

For monitoring TT-Sense® thrust, torque, shaft speed and power output only, we supply the PEM4 touch screen as a standalone unit.

Overview

Below table is a concise overview of the functionality of the various system solutions. For detailed information about each solution, we refer to the specific documentation.

	PEM4	PEM4 + SPU3	IVY®
User interface	Touch screen on ship	Touch screen on ship	Web application on any device
Visualisation of torque, shaft rpm, power, thrust and propeller quotient	x	x	x
Fuel consumption, SFOC, FOC	-	x	x
Ship speed (STW / SOG)	-	x	x
Zoom in on individual sensor signals	-	x	x
Conning screen incl. wind, trim and draft	-	x	x
Visualisation of KPIs	4	7	> 40
Data enrichment / Virtual sensors	-	-	x
Hull resistance (over time)	-	-	x
Propeller performance (over time)	-	-	x
Quantified additional FOC in \$ due to performance decrease	-	-	x
Integrated voyage reporting (eg. MRV)	-	-	x
Ship locations, track and heading	-	-	x
Compare sensor data	-	-	x
Compare ship's KPIs / sensor data	-	-	x
Fleet overview and performance	-	-	x

Technical specification

Control box for stator part

Power supply	115 or 230 VAC, 50 or 60 Hz \pm 20%
Power consumption	40 VA maximum
Input	2,4 GHz fully protected encrypted signal
Output	RS 485 for Modbus over TCP/IP or 4-20 mA isolated current output (optional)
Dimensions	408 x 360 x 111 mm

Rotor equipment

Material of mounting rings	Carbon steel
Material outside cover	Polyurea coated high density foam
Material compensator arms	Carbon steel
Shaft speed detection	Accelerometer signal
Output	2,4 GHz fully protected encrypted signal
Shaft diameter	Min. 200 mm, max. 1000 mm
Dimensions	Depending on shaft diameter
Operating temperature	-10°C to 60°C
Measuring tolerance	< 0,25% F.S.D. on torque < 1,0% F.S.D. on thrust

PEM4

Supply voltage	115 to 230 VAC to power supply unit
Power consumption	8 W in full activity
Temperature range	-20 to 60° C
Input	Ethernet signal from SPU3
Connections	RJ45 Ethernet connection on back (bottom side) of panel
Display color	TFT LCD, PCAP touch screen, 7.0" (1024 x 600 dots) with adjustable LED backlight
Dimensions	235 x 150 x 44 mm (w x h x d)
Cut out	217,6 x 128,6 mm (w x h)
Cut out depth	38 mm
Front panel thickness	6 mm
Protection class	IP 65 at front facia
Net weight	1,3 kg

SPU3

Supply voltage	115 to 230 VAC \pm 10%
Power consumption	60 W
Digital input	2x RS 485 Modbus connection for input signal from T-Sense® or TT-Sense® optical sensors and an additional NMEA input.
Analog input	9 x optional (galvanic isolated) 4-20mA, used for shaft generator input, auxiliary power or ViscoSense®3D
Pulse counter	Max. 12 Flowmeter pulse inputs 1x pulse input for speed log
PT100 input	Max. 12, used for fuel temperature compensation at Flowmeters.
Digital output	RJ45 Ethernet for connection to PEM4 touch screens or to a pc on board, either direct or via the ships network. RS 485 Modbus connection for data transfer to an external system like AMS (Alarm and Monitoring System) or for connection to a separate pc running PEM data logger software (optional)
Dimensions	660 x 300 x 165 mm (w x h x d)
Protection class	IP65
Net weight	Approx. 10 kg

Dimensions

TT-Sense®

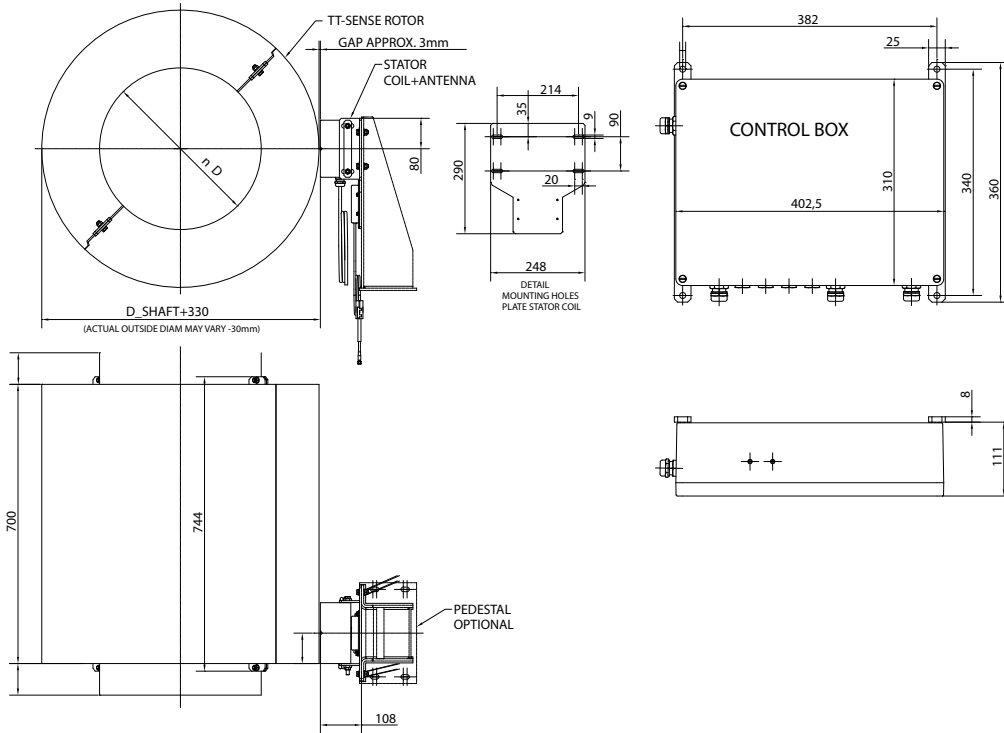

TT-Sense® optional components

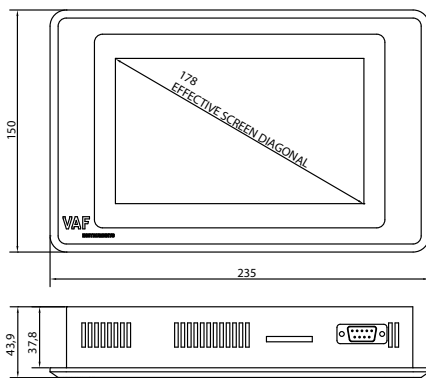

PEM4 touch screen

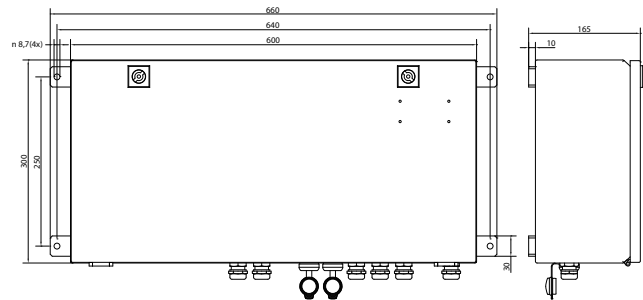

SPU3 Signal Processing Unit

Quotation and ordering information

1. Number of units:		
2. Available shaft length [mm]:		
3. Ship's name / hull:		
4. Please provide shaft line drawing for information:		
<input type="radio"/> new building		<input type="radio"/> retrofitting
5. Design conditions:		
power [kW]:		thrust [kN]:
speed [rpm]:		
shaft material:		shear modulus G [N/mm ²]:
		Young's modulus E [N/mm ²]:
shaft diameter (+tolerance) [mm]:		(min 200 mm)
inside (bore) diameter [mm]:		
duty		<input type="radio"/> propeller shaft
		<input type="radio"/> other:
6. System:		
required output	thrust	<input type="radio"/> RS 485/Modbus
		<input type="radio"/> range 4 - 20 mA = kN
torque		<input type="radio"/> RS 485/Modbus
		<input type="radio"/> range 4 - 20 mA = kNm
speed		<input type="radio"/> RS 485/Modbus
		<input type="radio"/> range 4 - 20 mA = rpm
power		<input type="radio"/> RS 485/Modbus
		<input type="radio"/> range 4 - 20 mA = kW
		<input type="radio"/> other:
options	<input type="radio"/> Propulsion Performance Management by IVW®	
	<input type="radio"/> PEM4 for Fuel Consumption Measurement, thrust, torque, shaft speed and power read-out	
	<input type="radio"/> touch screen display (PEM4) for thrust, torque, shaft speed and power read-out	

Name:

Place and date:

Please fill out this form and send it to sales@vaf.nl. We will reply with a quotation and ordering information for the requested product or solution a.s.a.p.

For further information see relevant Product Bulletins or www.vaf.nl



All copyrights reserved | PB-663-GB-1119 | Superseides PB-663-GB-0517

VAF

INSTRUMENTS

VAF Instruments B.V.
Vierlinghstraat 24, 3316 EL Dordrecht, The Netherlands
P.O. Box 40, 3300 AA Dordrecht, The Netherlands
T +31 78 618 3100 | info@vaf.nl | www.vaf.nl

Specifications subject to change without notice
VAF Instruments B.V. is an ISO 9001 Certified Company
Agents and distributors in more than 50 countries